

STAR FLEET BATTLES

GORN MASTER STARSHIP BOOK

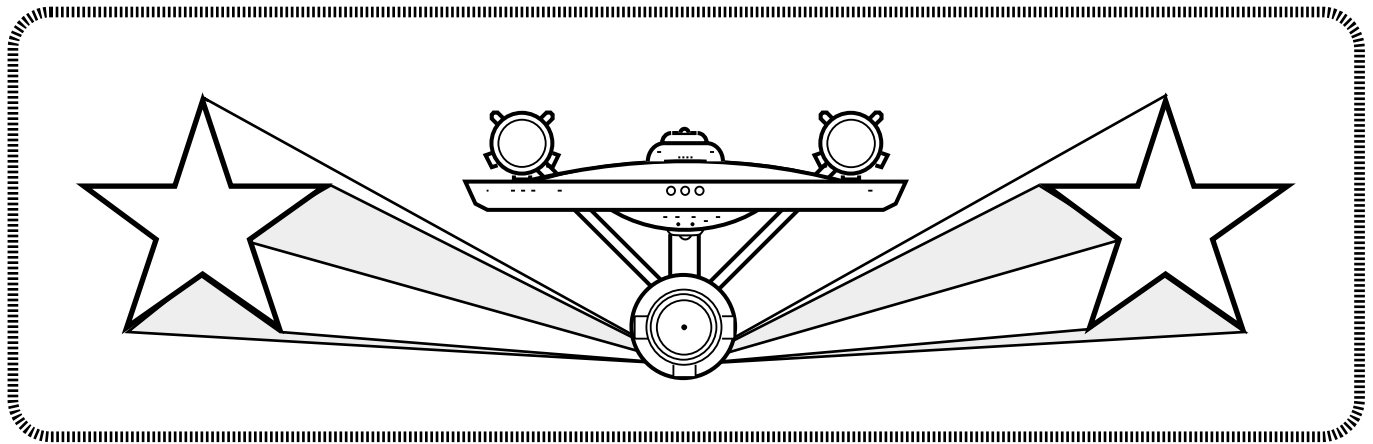

STAR FLEET BATTLES



CAPTAIN'S EDITION ★ GORN ★ MASTER STARSHIP BOOK

TABLE OF CONTENTS

INTRODUCTION

DESIGNER'S NOTES	2
PUBLISHER'S INFORMATION	2

GORN SHIPS

PUBLISHED MAIN ERA SHIPS	3
GORN SHIPS IN <i>CAPTAIN'S LOG</i>	51

GORN FIGHTERS AND BOMBERS

GORN FIGHTER DEVELOPMENT	56
GORN-FEDERATION BOMBERS	59
GORN-FEDERATION FIGHTERS	67
GORN SALAMANDER BOMBERS.....	71
GORN SHENYANG G-7	74
GORN FIGHTERS IN <i>CAPTAIN'S LOG</i>	74

GORN GROUND FORCES

COMPANY AND BATTALION TO&Es	77
VANGUARD TEAM ORGANIZATION	78

GORN FAST PATROL SHIPS

PTEROSAUR INTERCEPTORS.....	78
PTERODACTYL FAST PATROL SHIPS	79

GORN EARLY YEARS SHIPS

EARLY YEARS ERA SHIPS.....	83
----------------------------	----

GORN ADVANCED TECHNOLOGY SHIPS

ADVANCED TECHNOLOGY SHIPS.....	97
--------------------------------	----

GORN GENERAL UNITS

MAIN ERA GENERAL UNITS.....	102
GENERAL UNITS IN <i>CAPTAIN'S LOG</i>	124
EARLY YEARS ERA GENERAL UNITS.....	128
ADVANCED TECHNOLOGY GENERAL UNITS.....	138

CORRECTIONS

LIST OF CORRECTIONS FROM ORIGINAL PDF RELEASE.....	50
---	----

(Z56.0) NOTES ON THE GORN MASTER STARSHIP BOOK

(Z56.1) ORGANIZATION AND COMPONENTS

STAR FLEET BATTLES GORN MASTER STARSHIP BOOK is a modular expansion of the *SFB* game system. You will need the *SFB Basic Set* to use this material. This material will also require *Advanced Missions* and other products (e.g., *Module J, Module J2, Module K, Module M, Module R1, Module R4, Modules R5* through *R12, Module X1*, and *Module X1R*, and *Modules Y1* through *Y3*). to use it to the fullest extent. *The Gorn Master Starship Book* includes this 142-page book.

(Z56.2) DESIGN CREDITS

SFB Designer.....Stephen V. Cole, PE
Gorn MSSB Designer.....Steven P. Petrick, IN
 ProofreadingJean Sexton
 ADB Inspector General.....Miska
 Drill Sergeant.....Wolf
 Interior Artist.....Stephen V. Cole
 Gorn ArtDale McKee
 Confederation Researchers.....Howard Bampton, John Crawford, Stewart Frazier, Ken Kazinski, Ryan J. Opel

(Z56.3) PUBLISHER'S INFORMATION

This product is published by:
 AMARILLO DESIGN BUREAU, INC.
 POST OFFICE BOX 8759
 AMARILLO, TEXAS 79114-8759
 Telephone: 806-351-1950 (Fax: 806-351-2585)
 Email: Design@StarFleetGames.com
 Website: www.StarFleetGames.com

Include a stamped self-addressed envelope with all rules questions, submissions, or other inquiries. Most of the information which players seek (e.g., product schedules) is available free on our website.

All submissions are accepted only under our standard terms as published in *SFB Advanced Missions*. In summary, any submission becomes our property on receipt and may be modified at our sole discretion before publication. The author of a submission receives authorship credit and compensation at our standard rates.

ADB, Inc., products are available to individuals in retail stores, from several direct-mail outlets, from the shopping cart on our website, and directly from us. If your store does not carry our products, send us the store name and address and we will have our wholesalers contact the manager.

(Z56.4) DESIGNER'S NOTES

This product was born out of requests by our customers to have all of the non-SSD data about Gorn ship descriptions including their fighters, bombers, and fast patrol ships presented in one product to make it easier to look things up. All ships are in rule number order to make searching through the book for a specific unit as simple as any reference book.

The ship descriptions were formatted to include relevant refits applicable to a given unit, and special considerations, such as special sensors, whether a given ship is a carrier or fast patrol ship tender, scout or commando ship, or some or

all of these included. Commando ships were all spelled out as to their landing forces and whether or not they could, themselves, land on planets.

Further, all information that had been published in *Captain's Logs* as of the date this product was completed were also included. Ships prior to *Captain's Log #20* had all been published, but any unit that has not been formally published from *Captain's Log #20* through *Captain's Log #53* has been included.

This book also includes all Gorn ships which have been published from the Early Years, and those equipped with advanced technology.

As of its date of publication, this book is the most complete accounting of all Gorn ships, bombers, fighters, fast patrol ships, Interceptors, and ground forces organizations in the game system.

We hope that you enjoy this book and stay in touch.

You will notice on our webpage: www.StarFleetGames.com that you have several avenues to follow ADB. "Discuss" takes you to our BBS, where most of the game development takes place. "FC Forum" takes you to our Forum, which is more of a traditional forum to meet other players. You will also see that you can follow our page on Facebook (great for snippets of information and lots of art) and our Twitter account.

Want to find more players? Try our re-vamped Starlist: <https://www.starfleetgames.com/starlist.shtml> and we will send you a list of players near you.

As we say around here, "Don't be a stranger!"

DEDICATION: This book is dedicated to the Military Police. In peacetime they enforce the law on military installations. In war, they ensure the proper and steady movement of military convoys and provide protection to those convoys to ensure their arrival at their destinations. They secure not just those in our own ranks who violate the law, but also guard and safeguard those of the enemy who have fallen into our hands. They are always prepared to fight as light infantry should circumstances dictate, and are often the first responders when attacks and raids are made in the rear areas of our fighting fronts.

(Z56.5) COPYRIGHT & LICENSING

STAR FLEET BATTLES — CAPTAIN'S EDITION — GORN MASTER STARSHIP BOOK and all contents thereof are copyright © 2019 by ADB, Inc. All rights are reserved under the Pan-American, Berne, and International Copyright Conventions.

No material which is based on, for use with, incorporates elements of, or is derived from *Federation Commander, Star Fleet Battles, Federation & Empire, Star Fleet Missions, Star Fleet Battle Force, GURPS Prime Directive, Star Fleet Armada*, or the *Star Fleet Universe* background can be published by any party without the advanced written permission of ADB, Inc.

SFB is produced under license from Franz Joseph Designs, authors of the STAR FLEET TECHNICAL MANUAL.

Elements of the Star Fleet Universe are the property of Paramount Pictures Corporation and are used with their permission.